



US006726658B2

(12) **United States Patent**
Hochman

(10) **Patent No.:** **US 6,726,658 B2**
(45) **Date of Patent:** **Apr. 27, 2004**

- (54) **SAFETY IV CATHETER INFUSION DEVICE**
- (75) Inventor: **Mark N. Hochman**, Lake Success, NY (US)
- (73) Assignee: **Milestone Scientific, Inc.**, Livingston, NJ (US)
- (*) Notice: Subject to any disclaimer, the term of this patent is extended or adjusted under 35 U.S.C. 154(b) by 0 days.

D378,405 S	3/1997	Musgrave et al.
D381,418 S	7/1997	Erskine et al.
5,676,658 A	10/1997	Erskine
5,683,365 A	11/1997	Brown et al.
5,688,249 A	11/1997	Chang et al.
5,690,619 A	11/1997	Erskine et al.
5,700,250 A	12/1997	Erskine et al.
5,749,857 A	5/1998	Cuppy
5,755,709 A	5/1998	Cuppy
5,792,122 A	8/1998	Brimhall et al.
5,795,339 A	8/1998	Erskine
6,325,781 B1 *	12/2001	Takagi et al. 604/198

- (21) Appl. No.: **10/174,246**
- (22) Filed: **Jun. 18, 2002**
- (65) **Prior Publication Data**
US 2003/0233072 A1 Dec. 18, 2003

* cited by examiner

Primary Examiner—Brian L. Casler
Assistant Examiner—Catherine S. Williams
(74) *Attorney, Agent, or Firm*—Gottlieb, Rackman & Reisman, P.C.

- (51) **Int. Cl.**⁷ **A61M 5/178**; A61M 5/00; A61M 5/32
- (52) **U.S. Cl.** **604/164.08**; 604/110; 604/164.12; 604/188; 604/198
- (58) **Field of Search** 604/110, 164.01, 604/164.07, 164.08, 164.12, 165.01, 192, 194, 195, 196, 198, 199, 188; 128/919

(57) **ABSTRACT**

A device for delivering an IV catheter to an IV infusion site is disclosed. The device includes a cylindrical housing adapted to fit into the hand of the clinician. A catheter assembly is disposed in the housing and can be advanced to an extended position and retracted. The catheter assembly includes a needle adapted to be inserted into the vein and the catheter is mounted on the needle to allow the catheter to be removed at will. The catheter assembly is rotated as the needle is inserted into the vein. Preferably the catheter assembly is rotated during the insertion of the needle and catheter. After the needle and catheter are inserted into the vein, the needle is retracted into the housing leaving the catheter in place. The housing and the needle can now be discarded.

- (56) **References Cited**
U.S. PATENT DOCUMENTS
- 5,141,497 A 8/1992 Erskine
- 5,304,136 A 4/1994 Erskine et al.
- 5,348,544 A 9/1994 Sweeney et al.
- 5,411,486 A 5/1995 Zadini et al.
- 5,423,766 A 6/1995 Di Cesare
- 5,501,675 A 3/1996 Erskine
- 5,520,654 A 5/1996 Wahlberg

18 Claims, 3 Drawing Sheets

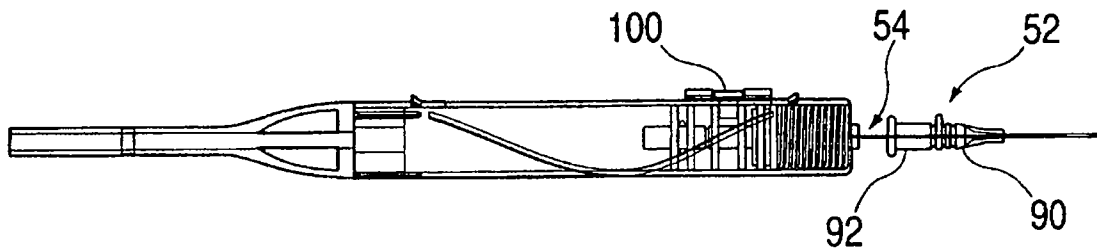

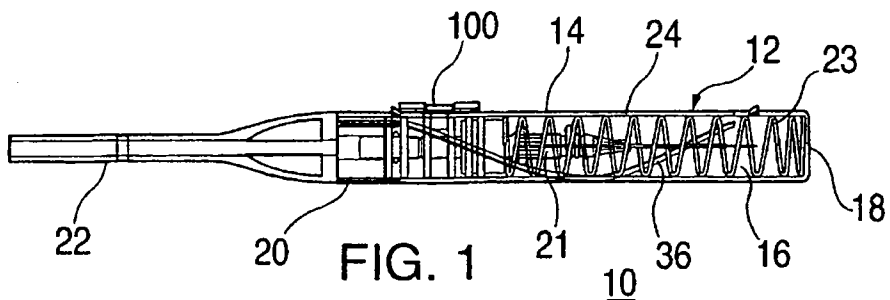

FIG. 1

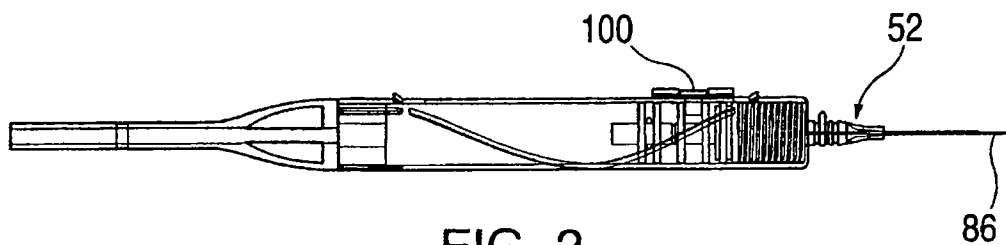

FIG. 2

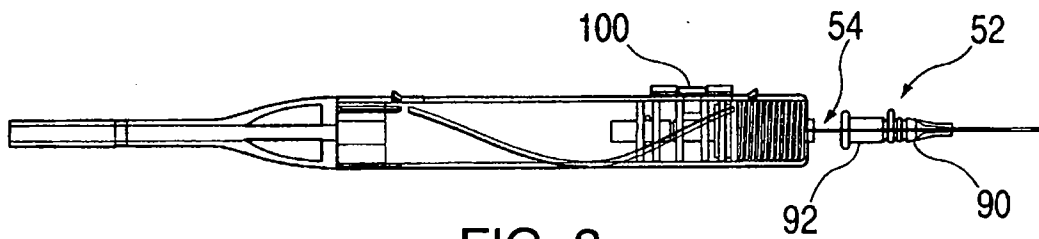

FIG. 3

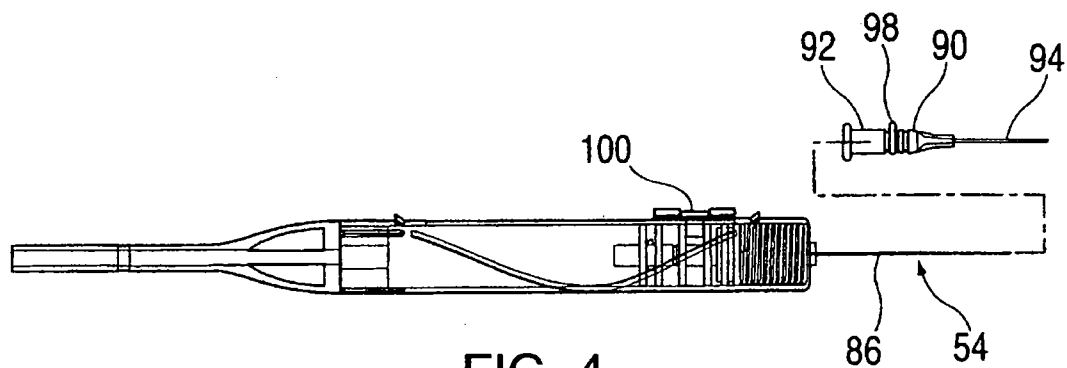

FIG. 4

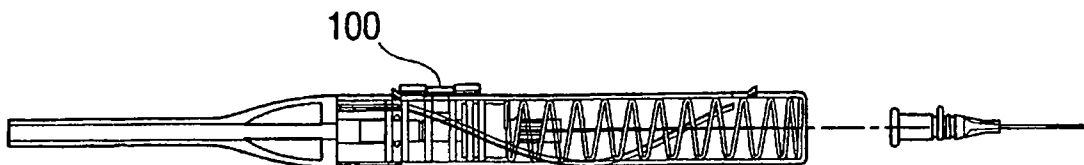

FIG. 5

