



US005903701A

# United States Patent [19]

[11] Patent Number: **5,903,701**

Lydecker et al.

[45] Date of Patent: **May 11, 1999**

[54] **METHOD AND APPARATUS FOR TESTING THE QUALITY OF RECORDED INFORMATION**

5,627,656 5/1997 Sonohara et al. .... 386/96  
5,629,980 5/1997 Stefik et al. .... 380/4  
5,732,183 3/1998 Sugiyama ..... 386/4

[75] Inventors: **George Lydecker, Burbank; Alan J. McPherson, Chatsworth, both of Calif.**

*Primary Examiner*—Robert Chevalier

[73] Assignee: **Warner Music Group, Inc., Olyphant, Pa.**

*Attorney, Agent, or Firm*—Gottlieb, Rackman & Reisman, P.C.

[21] Appl. No.: **09/102,425**

## [57] ABSTRACT

[22] Filed: **Jun. 22, 1998**

An ABX testing device for comparing for example two video or audio programs is provided to determine if the two programs can be distinguishable. The device selects randomly one of the programs and the tester can listen or view and compare sequentially the random selection to either of the programs. The tester then can vote by designating one of the programs as being the randomly selected program. The designations are accumulated and statistics are generated regarding the same. Preferably the device includes a control box, a switch mechanism and a PC coupled to both by standard parallel cable.

### Related U.S. Application Data

- [XX] .
- [60] Provisional application No. 60/057,176, Aug. 26, 1997.
- [51] Int. Cl.<sup>6</sup> ..... **H04N 5/91; H04N 5/93**
- [52] U.S. Cl. .... **386/46; 386/52; 348/705**
- [58] Field of Search ..... **386/46, 52, 92, 386/53, 4-98; H04N 5/91, 5/93, 5/268**

### [56] References Cited

#### U.S. PATENT DOCUMENTS

5,625,461 4/1997 Okamoto et al. .... 386/53

**25 Claims, 7 Drawing Sheets**

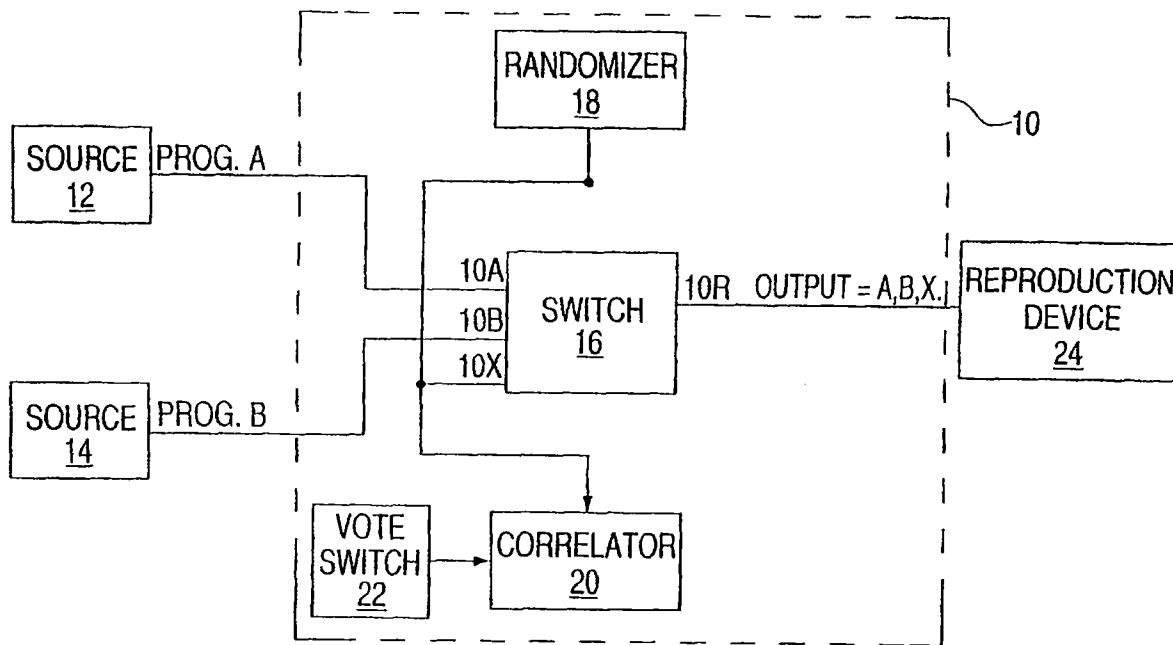

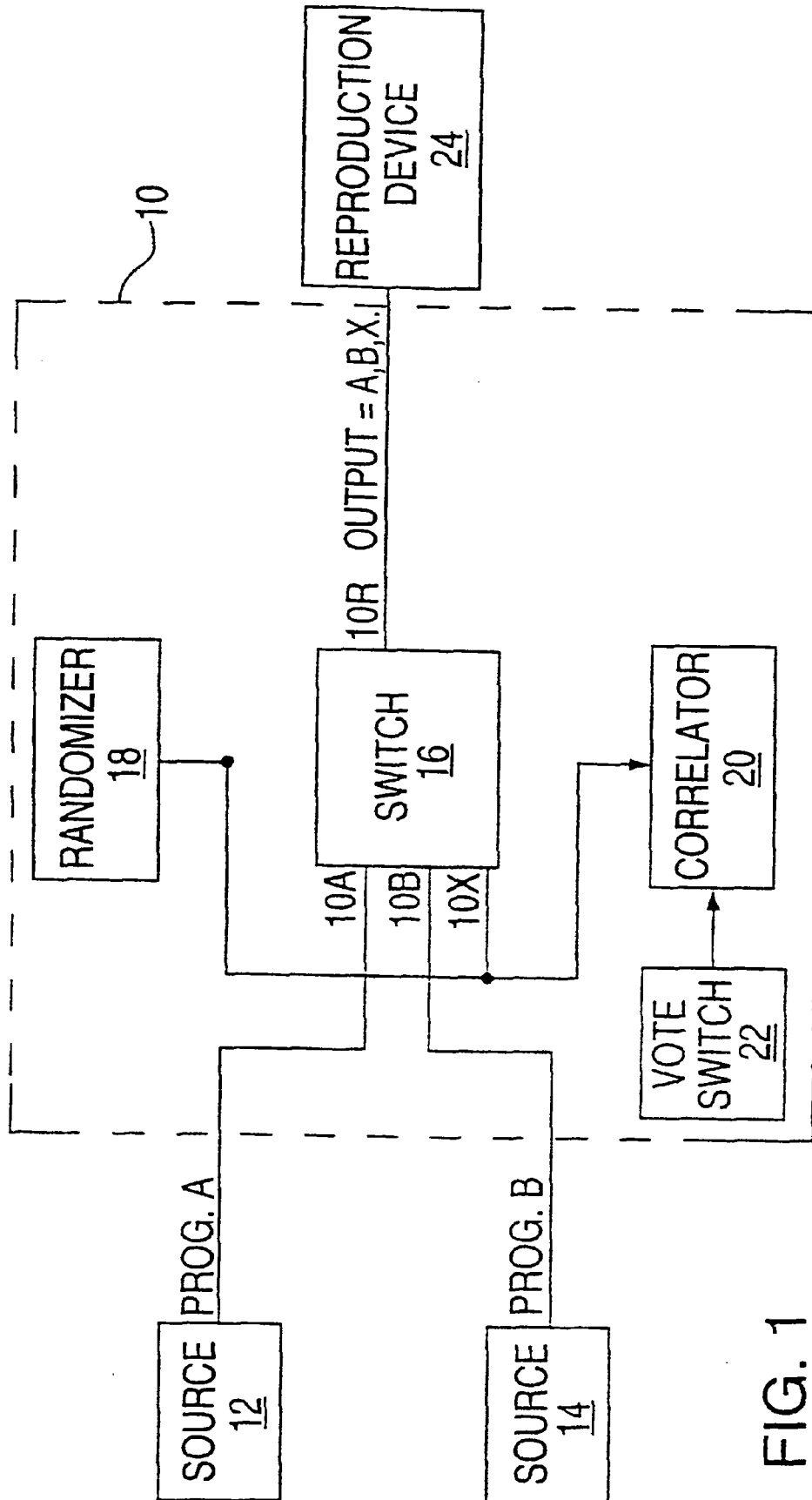

FIG. 1

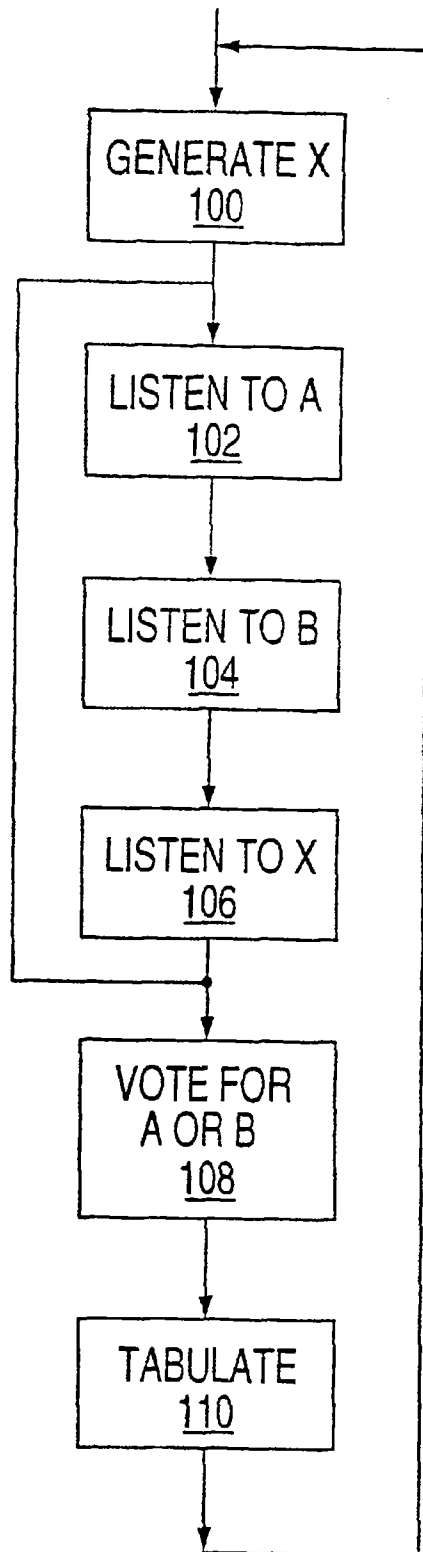

FIG. 2

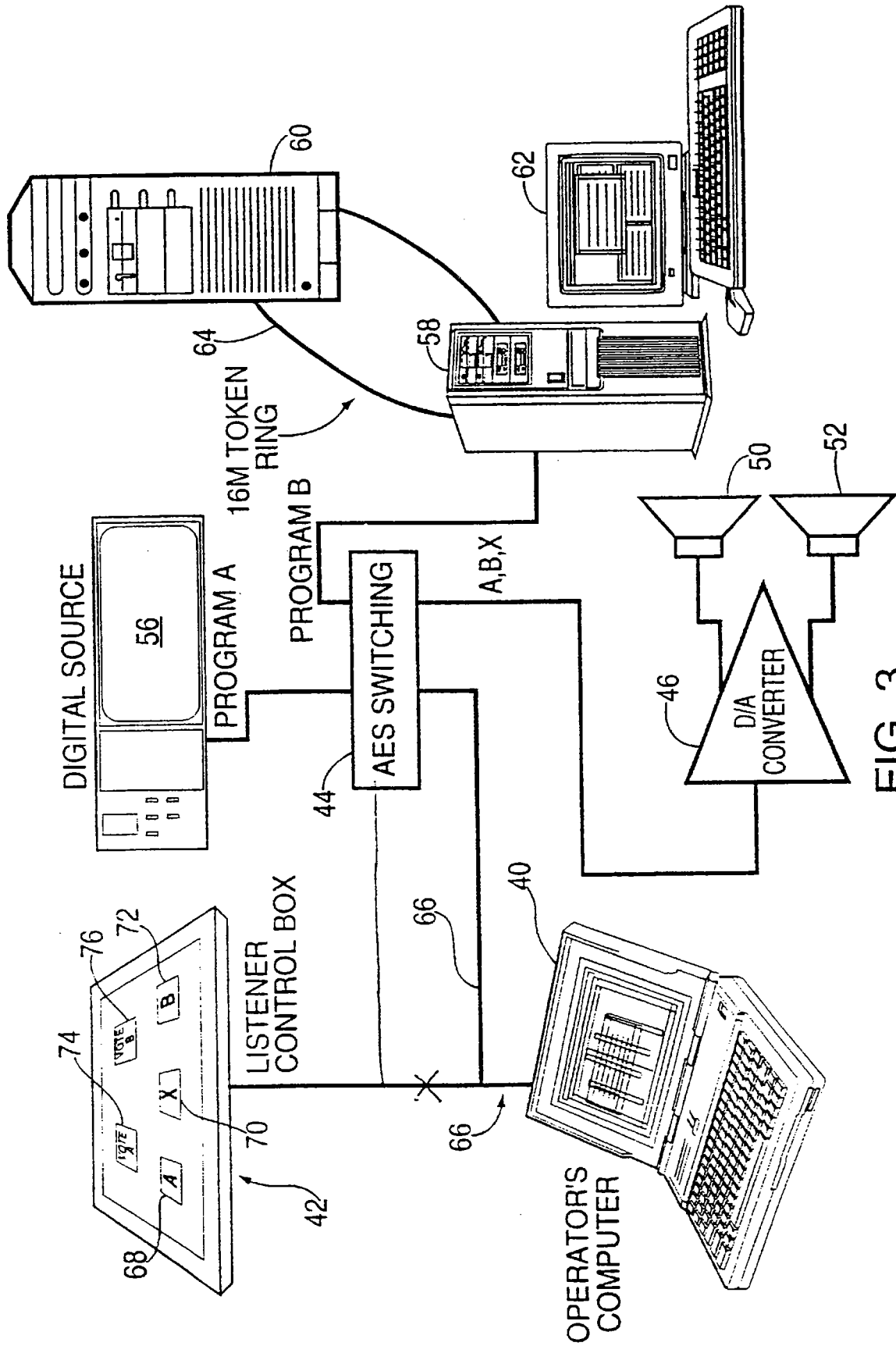

FIG. 3

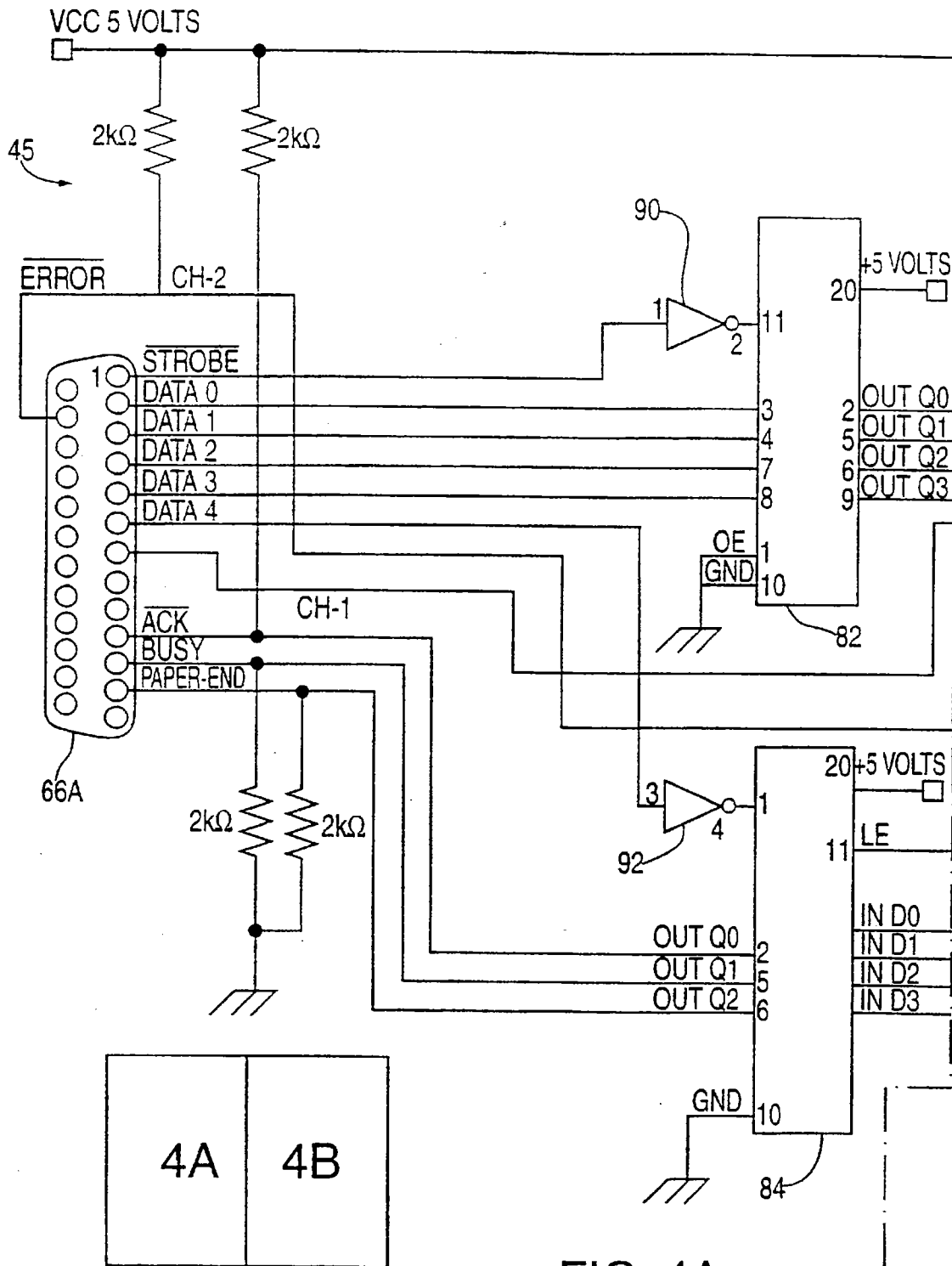

FIG. 4

FIG. 4A

