

Int. Cl.: 20

Prior U.S. Cls.: 2, 13, 22, 25, 32 and 50

United States Patent and Trademark Office

Reg. No. 2,894,980

Registered Oct. 19, 2004

**TRADEMARK
PRINCIPAL REGISTER**

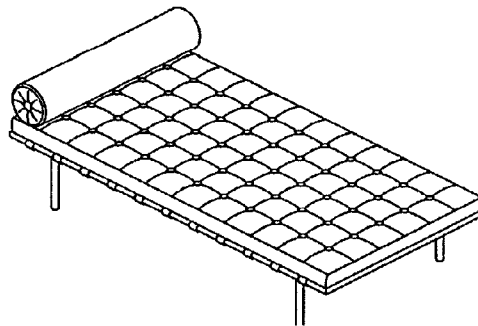

KNOLL, INC. (DELAWARE CORPORATION)
1235 WATER STREET
EAST GREENVILLE, PA 18041

FOR: COUCHES, IN CLASS 20 (U.S. CLS. 2, 13, 22,
25, 32 AND 50).

FIRST USE 1-1-1954; IN COMMERCE 1-1-1954.

THE MARK CONSISTS OF A CONFIGURATION
OF A COUCH WITH A METAL FRAME SUPPORT-
ING A LEATHER CUSHION.

SEC. 2(F).

SER. NO. 76-556,824, FILED 10-22-2003.

THEODORE MCBRIDE, EXAMINING ATTORNEY